

Microwave Integrated Circuits
Professor Jayanta Mukherjee
Department of electrical Engineering
Indian Institute of Technology Bombay
Lecture No 32
Amplifier Class, Frequency compensation

Another aspect of amplifier design which is the efficiency aspect. We all know that we want transistor in our amplifier to be highly efficient. We want that the total power consumed by our transistor is very less. So but then if we reduce the power, then we have to compensate or something. If we want the input and output relationships to remain perfectly same that are to be the input, if the input voltage is a sinusoid then the output voltage should also be a perfect final way.

If you want to ensure that and at the same time we want a higher efficiency, then we have to compensate, we have to cut corners on the output product. So that is how you know we can so by reducing the or by compromising on the quality of the current output, we can ensure that the efficiency of the amplifier is high. However, the voltage waveform remains the same.

(Refer Slide Time: 01:31)

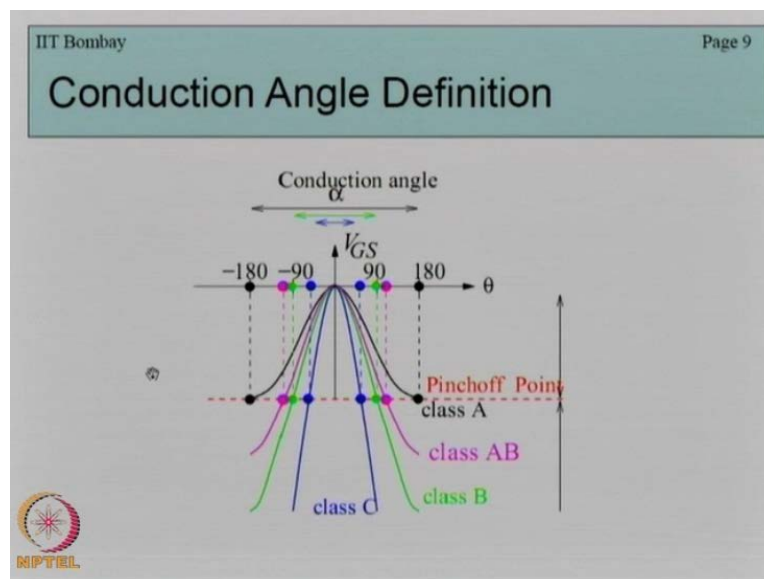

So depending on this, certain Classes of amplifiers have been formed. So here, if the transistor... Assuming that you know we have only a single transistor in an amplifier. So the transistor, the characteristics of the transistor that we use for this analysis is what we called ideal transistor characteristics.

(Refer SlideTime: 01:55)

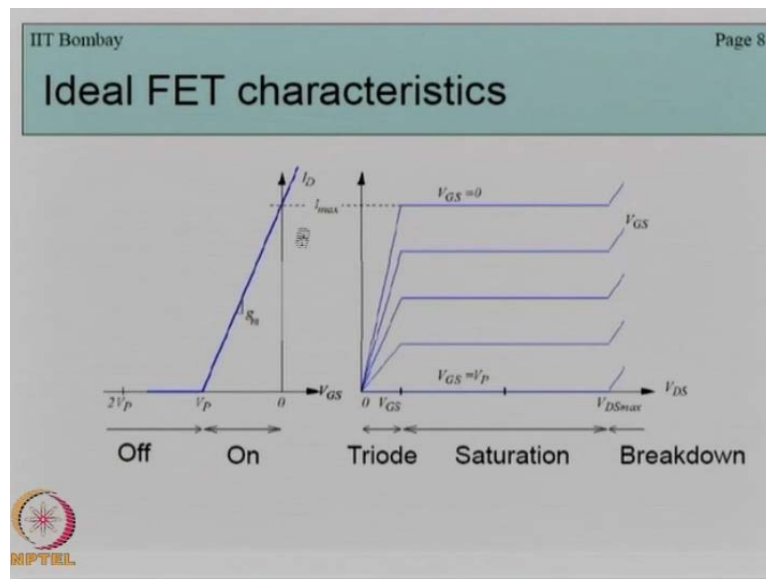

So this is a MOSFET whose drain current versus gate source voltage relationship is like this and whose drain current versus V D S that is drain source.

So this is, the previous 1 is the gate source voltage on the x-axis and this one has V D S drain source voltage around the x-axis. And as we know the characteristics can be divided into 2 minimum regions, the triode or the linear region and the saturation region.

(Refer SlideTime: 02:44)

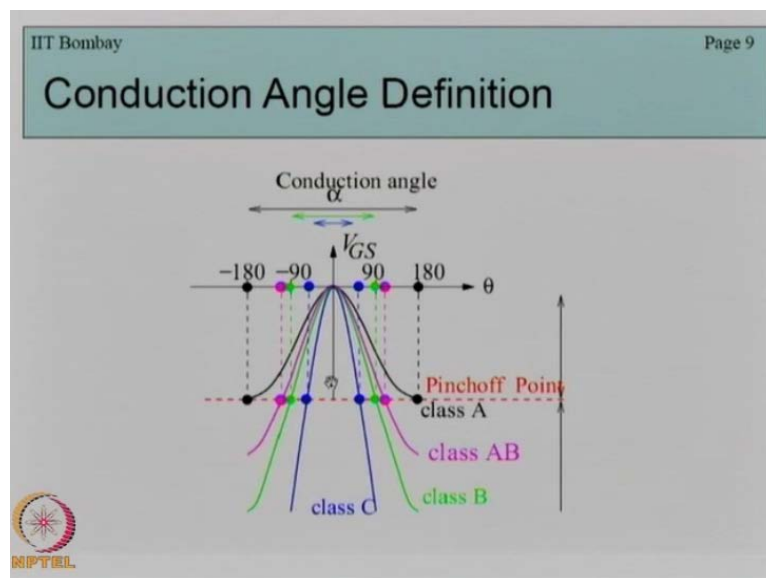

Now, depending on how, what angle or you know for what angle of a sinusoid the transistor is conducting, that is for what value of the input sinusoid or for what face values of the input sinusoid.

Our VGS is above the threshold voltage, we can Classify our amplifiers into Class A, Class AB and Class B and Class C, so 4 Classes we can achieve. So if our transistor is conducting for the entire 360 degree radiation, then it is called a Class A amplifier.

If it is conducting for phase between 180 degree and 360 degree, then it is called Class AB. If it is conducting for exactly 180 degree phase angle, then it is called Class B. And if it is conducting for less than 180 degree, then it is called Class C. So this is how we can classify.

(Refer SlideTime: 03:59)

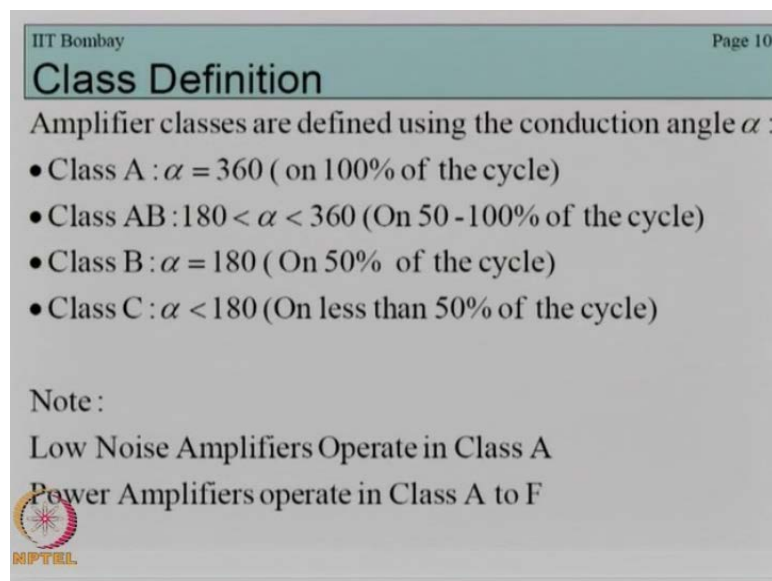

IIT Bombay Page 10

Class Definition

Amplifier classes are defined using the conduction angle α :

- Class A : $\alpha = 360$ (on 100% of the cycle)
- Class AB : $180 < \alpha < 360$ (On 50 -100% of the cycle)
- Class B : $\alpha = 180$ (On 50% of the cycle)
- Class C : $\alpha < 180$ (On less than 50% of the cycle)

Note :

Low Noise Amplifiers Operate in Class A
Power Amplifiers operate in Class A to F

 MPTCL

Now low noise amplifiers because they need to provide high in the input signal, so here we cannot compromise on current, so that is why low noise amplifiers... Excuse me... They usually operate in the Class A region. Power amplifiers on the other hand where signal purity is not so critical, we have a wide range of Classes from A to F.

Beyond the Class C, that is the Class D, Class E and Class F are called as switching amplifiers and they are a separate category. The conduction angle is not a factor over there. So let us see a Class A, a simple Class A amplifier, how it can be built.

This is a Class A amplifier with this is our MOSFET with load RD.

(Refer Slide Time: 04:52)

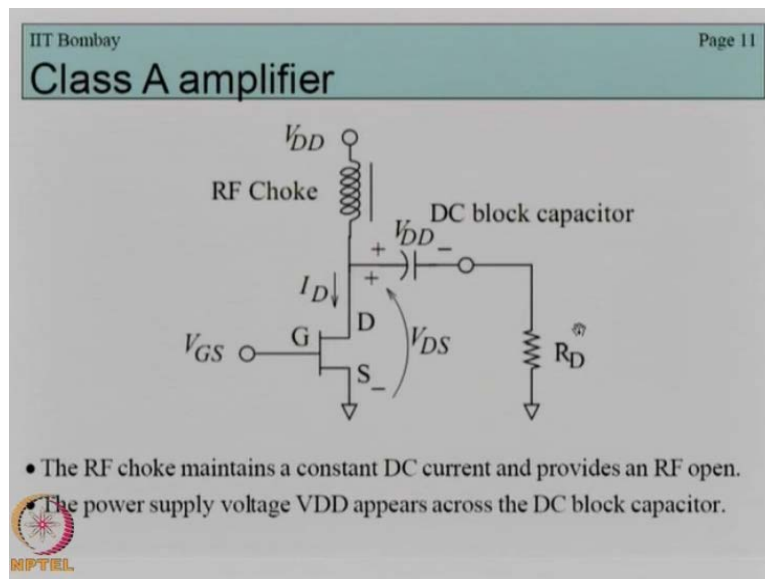

Now the operation of this Class A amplifier is like this.

(Refer SlideTime: 05:03)

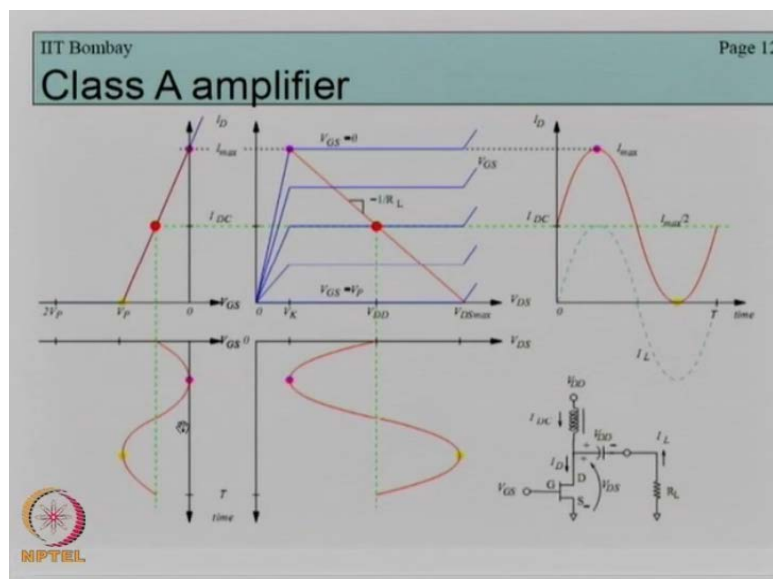

First of all, note that because it is operating for the entire region that is the transistor is always on, our input will have to be in that region of the I_D versus V_{GS} characteristics where the entire 360 degree can be accommodated.

So if our input amplitude is very high and suppose the negative part goes beyond this V_P somewhere around here, then it is not a Class A amplifier. So it is conducting for entire the entire 360 degree and similarly you know this is the input voltage and our I_D is also a perfect sinusoid, it conducts because V_{GS} is always on. Our I_D will also provide an output which

follows the input voltage. And finally our... Since our I_D is a sinusoid, our R_L will be I_D multiplied by R_L will be I_L multiplied by R_L and so that's why we get...

Our V_{DS} is a simply also a sinusoid like this. And this is basically our output voltage which is also a perfect sinusoid, so this is the Class A operation. Let us see what happens in Class B.

(Refer SlideTime: 06:52)

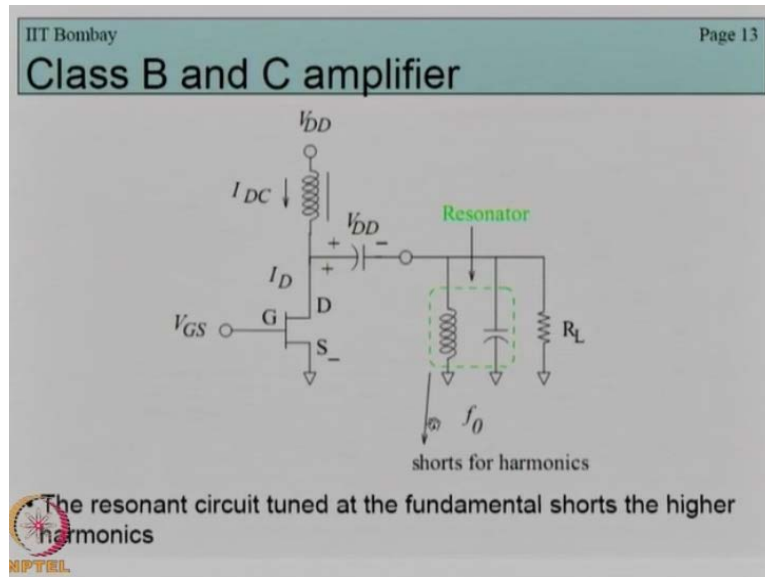

In Class B instead of just an R_L we now have a resonator with resonant frequency of f_0 connected in shunt with the load R_L . Remember that this ensures that the total DC current consumed from the source V_D is constant.

For the Class B as I said it conducts for exactly 180 degree.

(Refer Slide Time: 07:21)

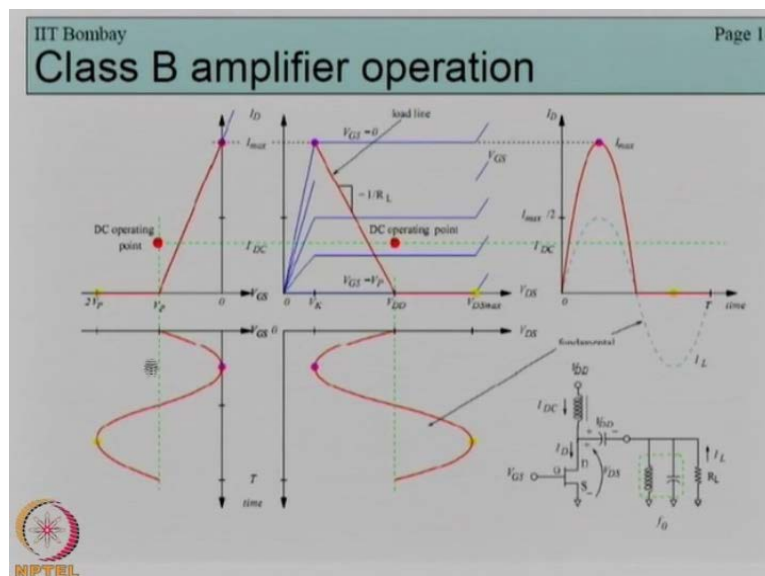

Therefore my input is now like this. See only the half cycle, only doing this life-cycle it lays the... The input lies in the conducting region of the transistor. Now because it is now conducting only for the half cycle, not how I_D changes. I_D is now like this, a single half cycle and then it stops. But what about my V_D V_D $D S$ my $V_D S$? $V_D S$ on the other hand continues to be a sinusoid.

There is no change in my output voltage characteristics. My output current characteristics changes. Recall that this half cycle is missing from I_D , but $V_D S$ continues to be a sinusoid just like before. And finally coming to Class C operation where the circuit is also exactly the same.

(Refer Slide Time: 08:30)

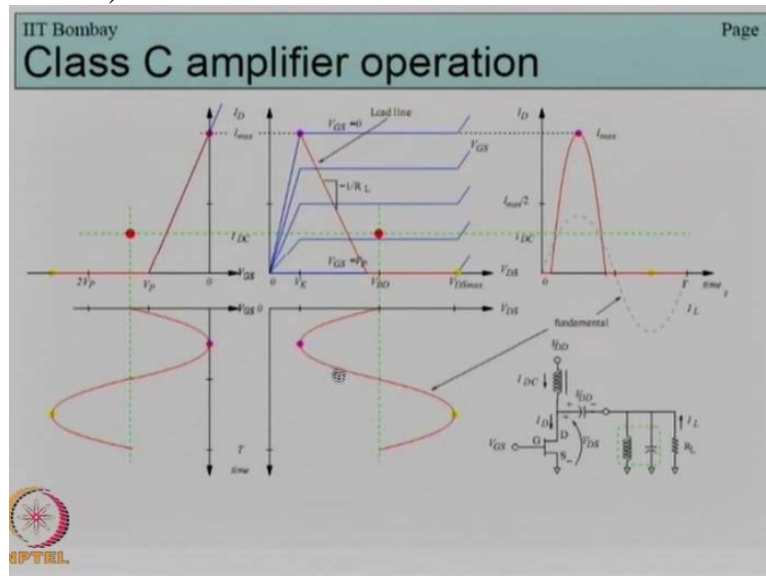

Here the only difference is that instead of this being fed for the half cycle; it is now being fed for less than half cycle.

$V_D S$ continues to remain a sinusoid and my I_D ... because my input voltage... because my transistor is conducting for less than half cycle less than 180 degree, the I_D is also conducting for a time period which is less than 180 degree. So this is how the working of this transistor happens, here of course note that my input and output voltage characteristics have remained the same. They are of course inverted and V input is rising we output is decreasing.

But the so you know when we say, sometimes it becomes confusing that whether the transistor is conducting Class AB, when I say that the that the voltage waveform as that when I say that the transistor is conducting say for Class B, I say that the transistor is conducting

for 180 degree. It appears as if the output voltage will also conduct for 180 degree, no, that is not the case.

The output voltage will keep on remaining the same. It is just that the output current changes. So you know so those are the few concepts that we introduce here. First was this bias, how-to bias a circuit, then how to operate... how to design transistor for it to be operating in the various Class A, Class AB and Class B regions, so that we get better efficiency in our circuit.

The next item I would like to cover is aspect of frequency compensation. So we know that as I was saying before that you know we design our circuit with at a particular frequency. But suppose we want to keep the gain constant. So one simple way to do that, suppose you know we have let's say a particular frequency f_1 gain like this, so this is my gain, this is frequency.

(Refer Slide Time: 11:24)

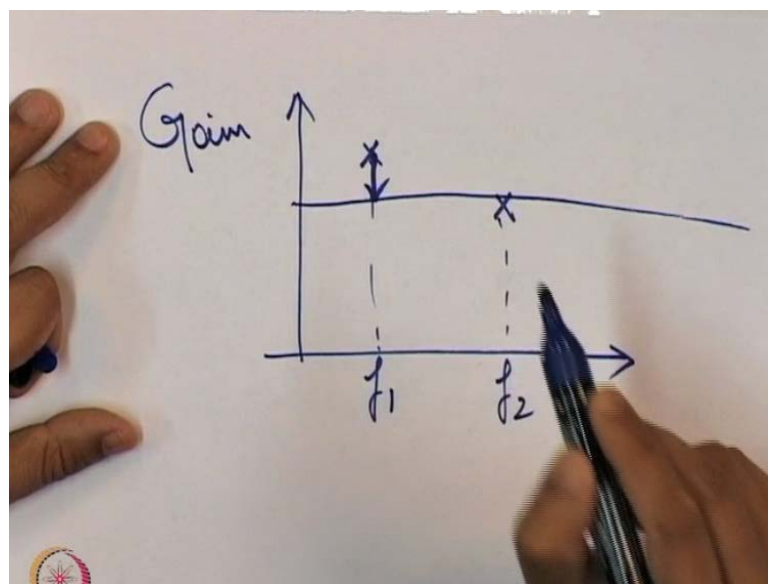

At a different frequency I have this as the gain, so how can I keep my gain constant? One way is to simply use the filter with a very broadband and bring this gain down, so that it matches with the gain of this one at this frequency. This way we are compensating, making the forcefully making the gain same over the entire range. Or you know so to do this what can we do in a so we have a higher gain at a different frequency.

(Refer Slide Time: 12:08)

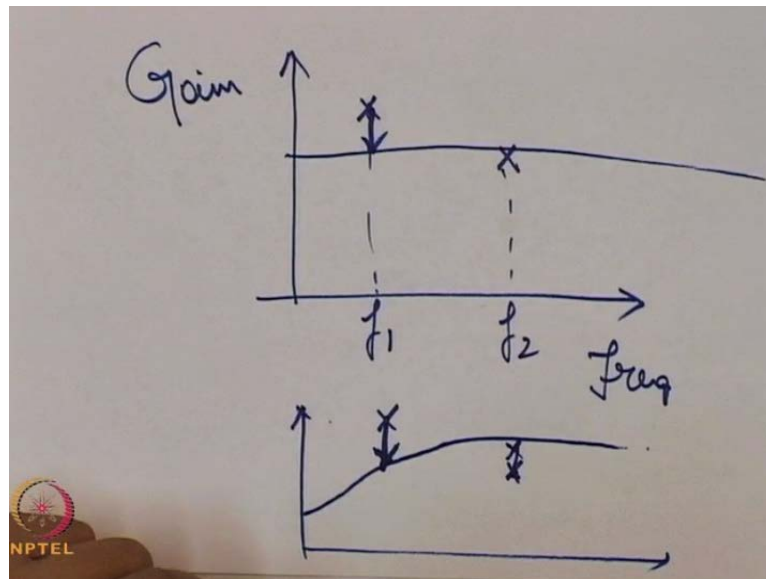

So we don't want to reduce the gain here, but we want to reduce the gain here. So if we choose a filter with a characteristics like this, what will happen is because the gain is low over here, this gain the inherent gain at a particular frequency will be brought down while the gain at the other frequency when we don't want it to be attenuated will continue remaining the same. Some example of yet another example if we take if we go to the slides on... if we go to the slides on the on the monitor.

(Refer slides Time: 12:51)

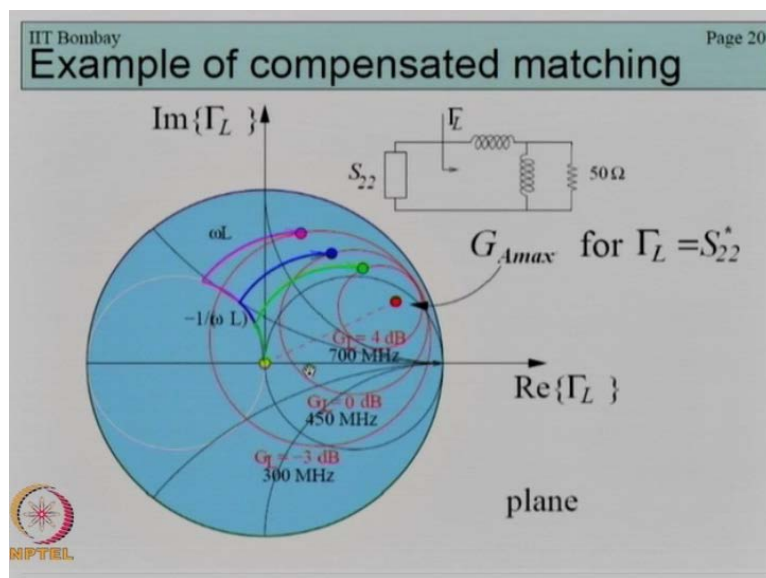

So here we have a matching network designed at a particular frequency. So you are the challenges that we have been given 3... so this table, please note this table.

(Refer Slide Time: 13:02)

IIT Bombay Page 19

Example of compensated matching

Assuming unilateral approximation applies :

$$G_{TU} = G_S |S_{21}|^2 G_L$$

Frequency MHz	G_{Smax} dB	$ S_{21} ^2$ dB	G_L dB	G_T dB
300	0.4	13	-3	10
450	0.33	10	0	10
700	1.77	6	4	10

- Little to be gained by matching the source
- Mismatch of the load is used to maintain a constant gain



This is the same unilateral design problem except that now it is for 3 different frequencies. So we have three different frequencies 300 Megahertz, 450 Megahertz and 700 Megahertz at 300 Megahertz we have we have S_{21} like this, G_{Smax} like this, G_L like this.

Now we see that by changing this input matching network or the source matching network, little can be gain because the G_{Smax} is very low anyway very low for all the 3 frequencies. on the other hand G_L has a lot of possibility for design and since we cannot do anything with the S_{21} square, so but we have to do is we have to make our G_L search that you know at it compensate for the variation in S_{21} square and we keep G_T equal to 10 dB for all three frequencies.

So once again I will repeat that G_{Smax} is this, since G_{Smax} is this since G_{Smax} value is less for all the three frequencies, so there is little to be gain while changing G_S . G_L on the other hand shows wide variations and so does S_{21} square. So based on this we see that if suppose at this S_{21} square we have a G_L equal to -3 at or at 300 Megahertz we have a G_L equal to -3 at 450 Megahertz we have G_L equal to 0.

And at 700 Megahertz we have G_L equal to 4. Then while designing G_L such that it takes these three values, we can compensate for the S_{21} square and ensure that the total gain is 10 dB for all three frequencies. So the way we do it is you know if this is the type of matching network.

(Refer Slide Time: 15:16)

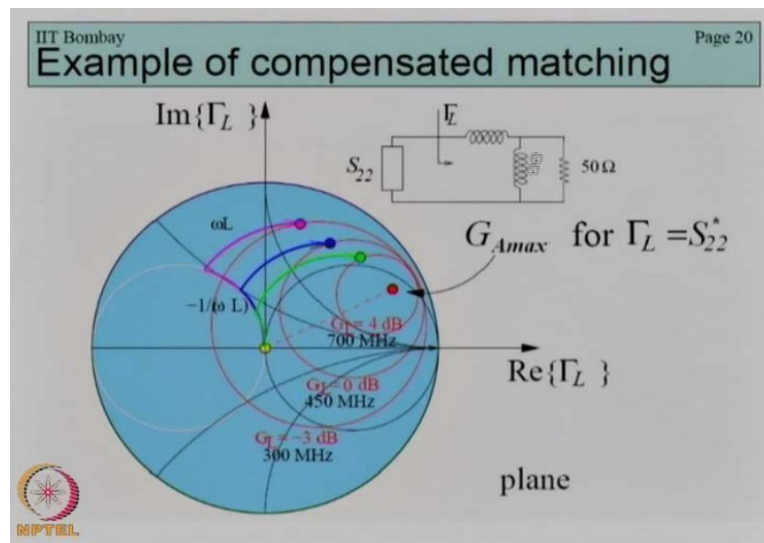

That is a shunt followed by a series combination of inductors is what we choose. Then we draw the G_L the G_L Circle for all three frequencies and this is what we find.

Now if we increase as we increase the frequency okay. Then you know how this kind of matching network how will it look on the Smith chart. This is an inductor in shunt, inductor in shunt means be move upwards along a constant conductance line and then there is a inductance in series which means we move up words along a constant resistance circle, so this green one represents say the variation or the locus as we travel away from the load of 50 ohms at 700 Megahertz

This blue one represents the same locus at 450 Megahertz and this pink one represents the same locus at 300 Megahertz. But we have to ensure is that on each travel for each for the travel for each frequency is or the path travelled by the locus at each frequency really ends up in the corresponding circle, so we saw that we need G_L equal to 4 dB at 700 Megahertz, we need G_L equal to 0 dB at 450 Megahertz and G_L equal to -3 dB at 300 Megahertz and that is what we are doing here.

We draw these circles corresponding G_L equal to -3 dB at 300 Megahertz, G_L equal to 0 dB at 450 Megahertz and G_L equal to 4dB at 700 Megahertz, so these are not the gain circle for different for the same frequency. They are gain circles on the same Smith chart but at different frequency and we see that that value of G_L ... no which satisfies all the three conditions is the matching network that we will choose.

So we keep on iterating with these various values of this inductance till we get a combination which for all these three frequencies will satisfy this locus condition. That is first we go upwards along a constant conductance circle and then upwards along a constant distance circle and we should meet the corresponding gain circle.

So by repeated iteration of these inductance values, we finally reach that value of inductance inductances which satisfies this condition. Now sometimes it is not always, it is not this method I said we can achieve this by iteration. Iteratively change the inductances so that compensation is achieved a constant gain is achieved for all three frequencies.

But this is somewhat dependent on luck also; it is not always that, nobody can guarantee that indeed we will find such a combination of inductances which can guarantee this uniformity of gain. So in that case where we cannot find such a solution, some things we can do to improve the gain or rather I should say the matching.

So one method that is frequently used is what is called the Ballard amplifier. If we go through the slides on the monitor, a balanced amplifier consists of 2 couplers, hybrid couplers or 90 degree couplers.

(Refer Slide Time: 19:32)

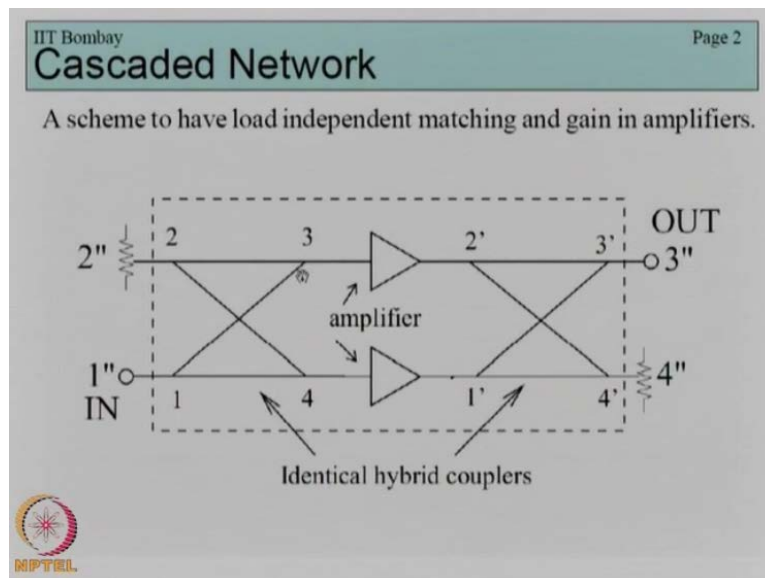

Recall that we have covered couplers previously and two identical amplifiers. Any signal that is inputted at Port 1 double dash, it will travel to both the inputs, both the amplifiers.

However, the reflected waves will come back only at 2 double dash, this we had already discussed you know while discussing the applications of couplers, we had covered this topic

earlier. So this is so the purpose of the balanced amplifier you see is that since for a very wide range of frequencies, the reflected waves will end up only at Port 2, hence we can achieve very broad band impedance matching.

The output impedance also can be matched over a very broad band by similar logic. Now, another kind of realization of a balanced amplifier is this.

(Refer Slide Time: 20:37)

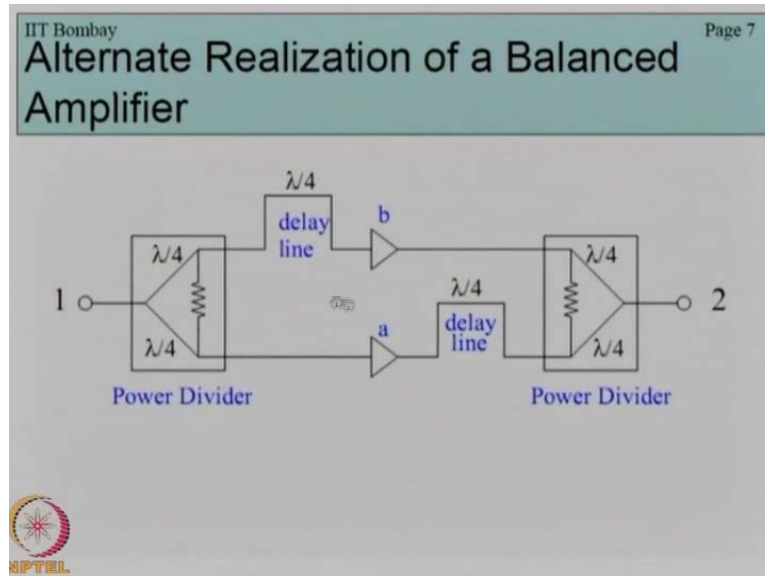

Now here what you have is a power divider recall we have covered power divider, 2 identical power dividers, 2 identical delay lines and 2 identical amplifiers.

It can be shown that the total input S_{11} here.

(Refer Slide Time: 20:57)

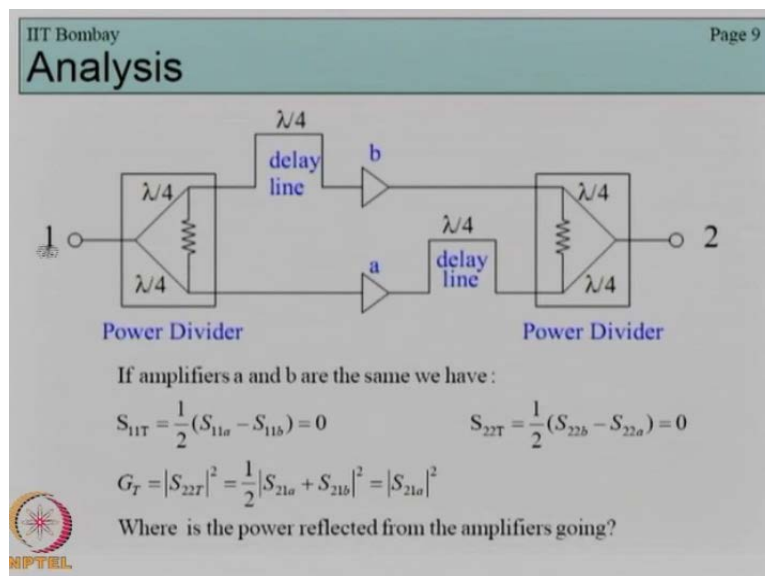

That is the total input reflection coefficient and output reflection coefficient will always be zero. Not when I say always I mean infinite bandwidth, it is not infinite but a very broadband kind of. Provided of course we have perfect matching between the amplifiers, perfect matching between the power dividers and perfect matching between the delay lines.

And you can also be shown that the total gain of this amplifier is equal to the square of the gain of any one of the two identical amplifiers. Now in both these balanced amplifiers.

(Refer Slide Time: 21:53)

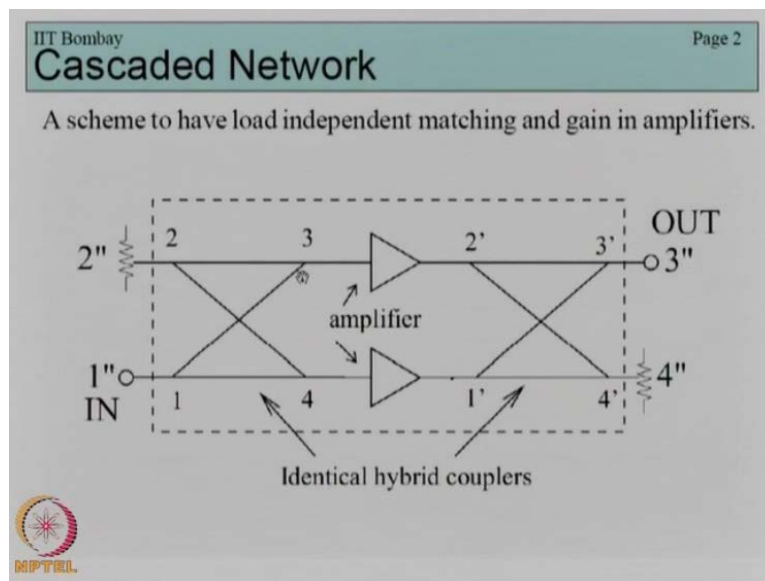

What is happening as I said in all the reflected waves are get added up at Port 2 dash, so there is a load match load connected at this Port 2 double dash where kind of the where the reflected powers are synced or wasted away.

Similarly, in this amplifier, the other amplifier that we are talking about, this amplifier.

(Refer Slide Time: 22:22)

IIT Bombay Page 9

Analysis

$S_{11T} = \frac{1}{2}(S_{11a} - S_{11b}) = 0$
 $S_{22T} = \frac{1}{2}(S_{22b} - S_{22a}) = 0$

$G_T = |S_{22T}|^2 = \frac{1}{2}|S_{21a} + S_{21b}|^2 = |S_{21a}|^2$

Where is the power reflected from the amplifiers going?

What happens is that here also reflections take place, but instead of coming back to the Port 1 or Port 2, they are kind of synced or wasted away in these in this resistant that is present in the power device, so in this but module will covered a number of topics especially on frequency compensation DC bias and also power and also broad band impedance matching as well as broadband gain matching.

There are some other aspects like associated with amplifier design like linearity and power combination, so that we will be covering in the next modules. Thank you.